

Write your name here

Surname

Other names

**Pearson Edexcel**  
**International**  
**Advanced Level**

Centre Number

--	--	--	--	--

Candidate Number

--	--	--	--

# Chemistry

**Advanced Subsidiary**

**Unit 1: The Core Principles of Chemistry**

Wednesday 10 January 2018 – Morning

**Time: 1 hour 30 minutes**

Paper Reference

**WCH01/01**

**Candidates must have: Scientific calculator**

Total Marks

## Instructions

- Use **black** ink or **black** ball-point pen.
- **Fill in the boxes** at the top of this page with your name, centre number and candidate number.
- Answer **all** questions.
- Answer the questions in the spaces provided  
– *there may be more space than you need.*

## Information

- The total mark for this paper is 80.
- The marks for **each** question are shown in brackets  
– *use this as a guide as to how much time to spend on each question.*
- Questions labelled with an **asterisk** (\*) are ones where the quality of your written communication will be assessed  
– *you should take particular care with your spelling, punctuation and grammar, as well as the clarity of expression, on these questions.*
- A Periodic Table is printed on the back cover of this paper.

## Advice

- Read each question carefully before you start to answer it.
- Try to answer every question.
- Check your answers if you have time at the end.
- Show all your working in calculations and include units where appropriate.

Turn over ►

P50704A

©2018 Pearson Education Ltd.

6/5/5/1/1/1/



Pearson

## SECTION A

Answer ALL the questions in this section. You should aim to spend no more than 20 minutes on this section. For each question, select one answer from A to D and put a cross in the box . If you change your mind, put a line through the box  and then mark your new answer with a cross .

1 The diagram shows a mass spectrometer.

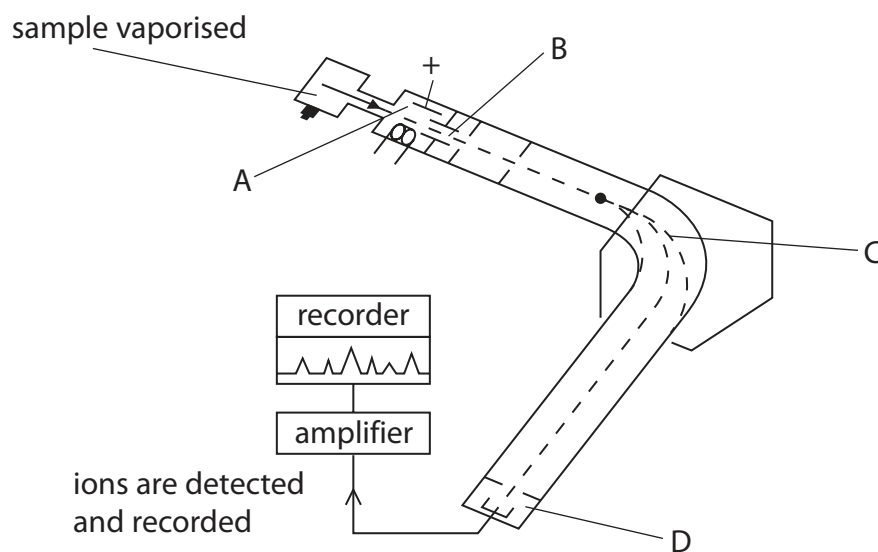

The region of the mass spectrometer in which ions are accelerated is

(1)

- A A
- B B
- C C
- D D

(Total for Question 1 = 1 mark)

2 The electronic configuration of the nitride ion,  $\text{N}^{3-}$ , is

- A  $1s^2 2s^2$
- B  $1s^2 2s^2 2p^1$
- C  $1s^2 2s^2 2p^3$
- D  $1s^2 2s^2 2p^6$

(Total for Question 2 = 1 mark)



3 W, X, Y and Z represent four elements in the Periodic Table. These are not the symbols for the elements.

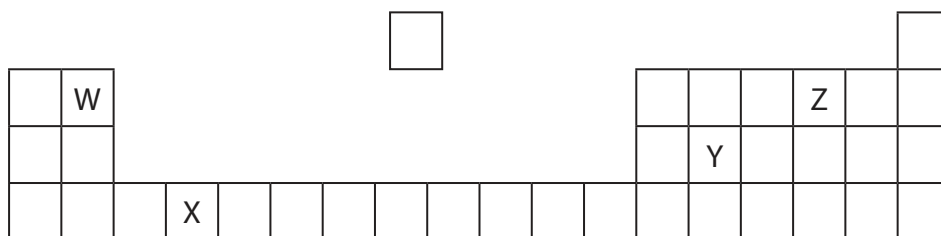

(a) Which is a p block element with only two electrons in its outer p subshell?

(1)

- A W
- B X
- C Y
- D Z

(b) Elements **W** and **Z** form a compound **WZ**. The types of bonding in **W**, **Z** and **WZ** are

(1)

	W	Z	WZ
<input type="checkbox"/> A	ionic	covalent	ionic
<input type="checkbox"/> B	metallic	covalent	ionic
<input type="checkbox"/> C	metallic	covalent	covalent
<input type="checkbox"/> D	metallic	ionic	covalent

(Total for Question 3 = 2 marks)

Use this space for any rough working. Anything you write in this space will gain no credit.



P 5 0 7 0 4 A 0 3 2 4

4 Alstonite is a rare salt with the formula,  $\text{BaCa}(\text{CO}_3)_2$ . It reacts with hydrochloric acid.

Data: molar mass of alstonite =  $297.4 \text{ g mol}^{-1}$

$$L = 6.02 \times 10^{23} \text{ mol}^{-1}$$

(a) The percentage by mass of oxygen in alstonite is

(1)

- A 16.1%
- B 26.9%
- C 32.3%
- D 34.3%

(b) What is the **total** number of ions in one mole of alstonite?

(1)

- A  $6.02 \times 10^{23}$
- B  $1.20 \times 10^{24}$
- C  $1.81 \times 10^{24}$
- D  $2.41 \times 10^{24}$

(c) What is the number of moles of hydrochloric acid required for complete reaction with one mole of alstonite?

(1)

- A one
- B two
- C three
- D four

(Total for Question 4 = 3 marks)

Use this space for any rough working. Anything you write in this space will gain no credit.

DO NOT WRITE IN THIS AREA

DO NOT WRITE IN THIS AREA

DO NOT WRITE IN THIS AREA

DO NOT WRITE IN THIS AREA

DO NOT WRITE IN THIS AREA

DO NOT WRITE IN THIS AREA



5 Phosphorus reacts with iodine to produce phosphorus(III) iodide:

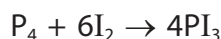

What is the minimum mass of iodine required to produce 1 kg of phosphorus(III) iodide when the phosphorus is in excess?

Data: molar mass of phosphorus(III) iodide =  $411.7 \text{ g mol}^{-1}$

- A 0.616 kg
- B 0.925 kg
- C 2.466 kg
- D 3.700 kg

(Total for Question 5 = 1 mark)

6 Sulfur reacts with chlorine to produce disulfur dichloride:

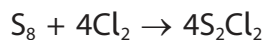

What is the maximum mass of disulfur dichloride that could be produced from the reaction of 0.100 mol of sulfur,  $\text{S}_8$ , with 0.394 mol of chlorine?

Data: molar mass of disulfur dichloride =  $135.2 \text{ g mol}^{-1}$

- A 13.32 g
- B 13.52 g
- C 53.27 g
- D 54.08 g

(Total for Question 6 = 1 mark)

7 Which of these Period 2 elements has the highest melting temperature?

- A Lithium
- B Boron
- C Nitrogen
- D Neon

(Total for Question 7 = 1 mark)



P 5 0 7 0 4 A 0 5 2 4

8 Chlorine can be prepared by the reaction between concentrated hydrochloric acid and concentrated sodium chlorate(I).  
Chlorine is a hazardous substance and the risk due to the chlorine is best lowered by

- A using a fume cupboard.
- B wearing gloves.
- C wearing goggles.
- D working in groups.

(Total for Question 8 = 1 mark)

9 Metallic bonding is best described as the electrostatic attraction between

- A cations and anions.
- B cations and delocalised electrons.
- C nuclei and shared pairs of electrons.
- D nuclei and two electrons from one atom.

(Total for Question 9 = 1 mark)

10 The ionic equation for the reaction between hydrochloric acid and aqueous sodium hydroxide is

- A  $\text{H}^+(\text{aq}) + \text{OH}^-(\text{aq}) \rightarrow \text{H}_2\text{O}(\text{l})$
- B  $\text{Cl}^-(\text{aq}) + \text{Na}^+(\text{aq}) \rightarrow \text{NaCl}(\text{aq})$
- C  $\text{H}^+(\text{aq}) + \text{Cl}^-(\text{aq}) + \text{Na}^+(\text{aq}) + \text{OH}^-(\text{aq}) \rightarrow \text{Cl}^-(\text{aq}) + \text{Na}^+(\text{aq}) + \text{H}_2\text{O}(\text{l})$
- D  $\text{H}^+(\text{aq}) + \text{Cl}^-(\text{aq}) + \text{Na}^+(\text{aq}) + \text{OH}^-(\text{aq}) \rightarrow \text{NaCl}(\text{aq}) + \text{H}_2\text{O}(\text{l})$

(Total for Question 10 = 1 mark)

Use this space for any rough working. Anything you write in this space will gain no credit.

DO NOT WRITE IN THIS AREA

DO NOT WRITE IN THIS AREA

DO NOT WRITE IN THIS AREA

DO NOT WRITE IN THIS AREA

DO NOT WRITE IN THIS AREA

DO NOT WRITE IN THIS AREA



11 Methane reacts with chlorine in the presence of UV radiation to produce chloromethane:

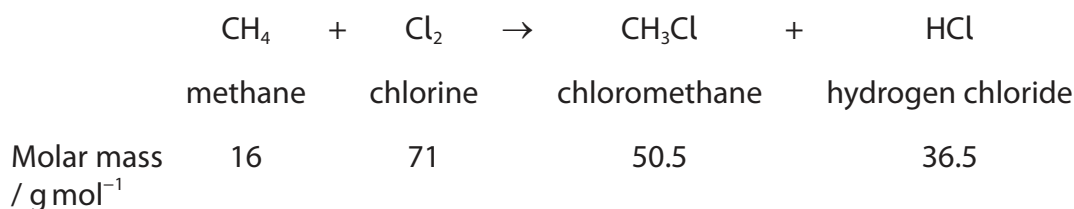

(a) What is the atom economy by mass for the production of chloromethane in this reaction?

(1)

- A 29%
- B 42%
- C 58%
- D 71%

(b) When 3.20 g of methane reacted with excess chlorine, 5.05 g of chloromethane was made. What was the percentage yield?

(1)

- A 10%
- B 20%
- C 50%
- D 63%

(c) A methyl free radical forms in this reaction. The dot-and-cross diagram for the methyl free radical is

(1)

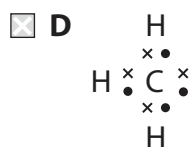
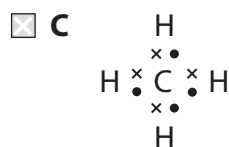
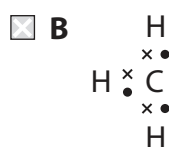
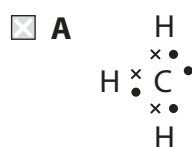

(Total for Question 11 = 3 marks)





- 12 Hess's law can be used to determine enthalpy changes, such as the formation of carbon monoxide from carbon and oxygen, which cannot be obtained directly.

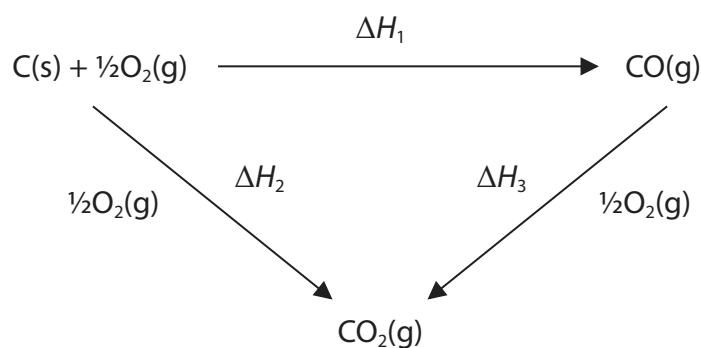

From Hess's law

- A  $\Delta H_1 = \Delta H_2 - \Delta H_3$
- B  $\Delta H_1 = \Delta H_2 + \Delta H_3$
- C  $\Delta H_1 = \frac{1}{2}\Delta H_2 - \frac{1}{2}\Delta H_3$
- D  $\Delta H_1 = \frac{1}{2}\Delta H_2 + \frac{1}{2}\Delta H_3$

(Total for Question 12 = 1 mark)

- 13 Consider the bond enthalpy values given in the table.

Bond	Bond enthalpy / $\text{kJ mol}^{-1}$
$\text{N}\equiv\text{N}$	+945
$\text{H}-\text{H}$	+436
$\text{N}-\text{H}$	+391

For the reaction

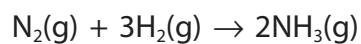

the enthalpy change, in  $\text{kJ mol}^{-1}$ , is

- A +1080
- B +852
- C -93
- D -529

(Total for Question 13 = 1 mark)





**14** The enthalpy change of combustion of ethanol was determined by using a spirit burner containing ethanol to heat 250 cm<sup>3</sup> of water in a copper calorimeter. The experimental value obtained was less exothermic than the Data Booklet value.

Which is the **least** likely reason for this difference in the enthalpy values?

- A** Heat loss from the copper calorimeter
- B** Incomplete combustion of the ethanol
- C** Use of non-standard conditions
- D** Loss of ethanol by evaporation

**(Total for Question 14 = 1 mark)**

**15** A drop of copper(II) sulfate solution was placed at the centre of a damp piece of filter paper covering a microscope slide. A direct current was passed through the paper and after a short time the following observations were noted:

	Moving towards the anode	Moving towards the cathode
<input type="checkbox"/> <b>A</b>	blue colour	nothing visible
<input type="checkbox"/> <b>B</b>	blue colour	yellow colour
<input type="checkbox"/> <b>C</b>	yellow colour	blue colour
<input type="checkbox"/> <b>D</b>	nothing visible	blue colour

**(Total for Question 15 = 1 mark)**

**TOTAL FOR SECTION A = 20 MARKS**



## SECTION B

Answer ALL the questions. Write your answers in the spaces provided.

- 16 This question is about alkanes and their use as fuels.  
Crude oil is a mixture of alkanes which can be processed in various ways.

- (a) Fractional distillation is the method used to separate crude oil into fractions containing similar sized alkanes.

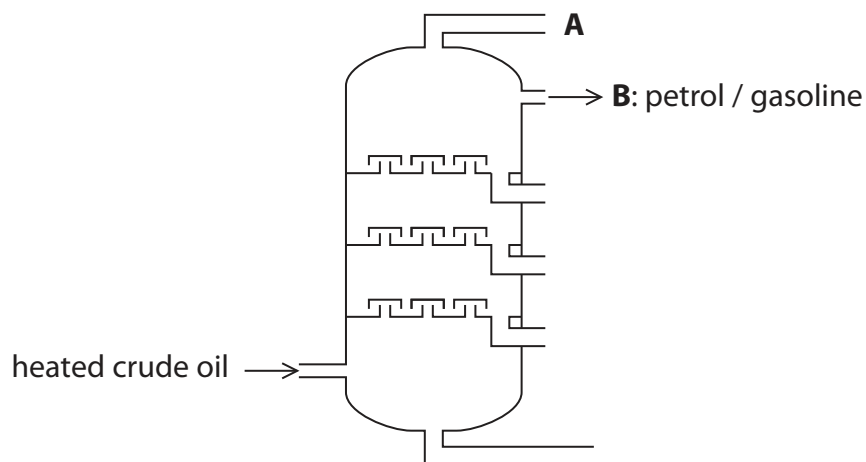

- (i) On what physical property does the separation of alkanes using fractional distillation depend?

(1)

---

---

- (ii) Suggest the name of an alkane that would be present in the fraction labelled **A**.

(1)

---

---

- (iii) State why fractions in addition to **B** are also processed to produce petrol.

(1)

---

---

DO NOT WRITE IN THIS AREA

DO NOT WRITE IN THIS AREA

DO NOT WRITE IN THIS AREA

DO NOT WRITE IN THIS AREA

DO NOT WRITE IN THIS AREA

DO NOT WRITE IN THIS AREA



(b) Substances obtained from crude oil can be processed by cracking to obtain alkanes and alkenes.

(i) Industrial catalysts are used for the cracking process. What other condition is required?

(1)

(ii) The kerosene fraction contains the hydrocarbon,  $C_{12}H_{26}$ , which can be cracked to produce octane and ethene **only**.

Write the equation for this cracking reaction. State symbols are not required.

(2)

(c) Substances obtained from crude oil can be processed by reforming to produce branched-chain alkanes from straight-chain alkanes.

(i) State the advantage of using petrol containing branched-chain alkanes.

(1)

(ii) Using **skeletal** formulae, write an equation for the reforming of hexane into an alkane with a single branch as the only product. Name your product. State symbols are not required.

(3)

Name .....

(iii) Reforming can also produce cyclic alkanes from straight-chain alkanes. Complete the equation for the reforming of nonane into propylcyclohexane.

(1)

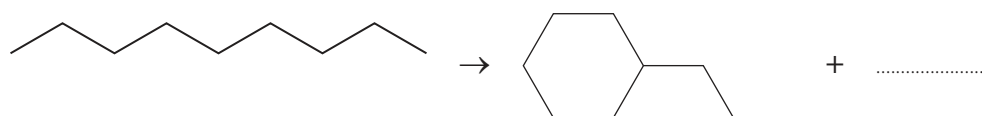

(d) Pentane, C<sub>5</sub>H<sub>12</sub>, is used as a fuel.

- (i) Calculate the volume of carbon dioxide produced at room temperature and pressure (r.t.p.) from the complete combustion of 10.0 cm<sup>3</sup> of liquid pentane. Give your answer to **three** significant figures.

Data: one mole of any gas occupies 24 000 cm<sup>3</sup> at r.t.p.  
density of liquid pentane = 0.626 g cm<sup>-3</sup>



(4)

- (ii) Write an equation for the incomplete combustion of pentane to form carbon monoxide and water **only**. State symbols are not required.

(1)

- \* (e) Crude oil is a non-renewable resource and some chemists are of the opinion that, because its use causes climate change, other energy sources should be used.

Explain the meaning of the term 'non-renewable' and how the use of crude oil causes climate change.

(2)

.....

.....

.....

.....

.....

.....

(Total for Question 16 = 18 marks)



DO NOT WRITE IN THIS AREA

DO NOT WRITE IN THIS AREA

DO NOT WRITE IN THIS AREA

DO NOT WRITE IN THIS AREA

DO NOT WRITE IN THIS AREA

DO NOT WRITE IN THIS AREA

17 This is a question about the structure and chemical properties of alkenes.

(a) The carbon-carbon double bond consists of both a sigma ( $\sigma$ ) bond and a pi ( $\pi$ ) bond.

(i) Describe **two** differences in the orbital overlap of a sigma bond and in the orbital overlap of a pi bond between carbon atoms.

(2)

.....

.....

.....

.....

.....

.....

.....

.....

.....

.....

.....

.....

.....

.....

.....

.....

.....

.....

.....

.....

.....

.....

.....

(ii) What feature of a pi bond can result in *E-Z* isomers?

(1)

.....

.....





(ii) Draw the repeat unit of the polymer formed from propene.

(1)

(c) Draw the mechanism for the reaction between hydrogen bromide and propene to form the **major** product.

- Use curly arrows and show any relevant dipoles and lone pairs of electrons
- State the name of the reaction mechanism
- Give the name of the **major** product.

(6)

Reaction mechanism .....

Name of **major** product .....

(Total for Question 17 = 17 marks)





18 Ionisation energies provide evidence for the electronic structures of atoms.

(a) Complete the definition of the term first ionisation energy.

(2)

The energy required to remove one electron from each atom .....

.....

.....

(b) Explain why ionisation is an endothermic process.

(1)

.....

.....

(c) The sketch below shows the first ionisation energies of nine successive elements.

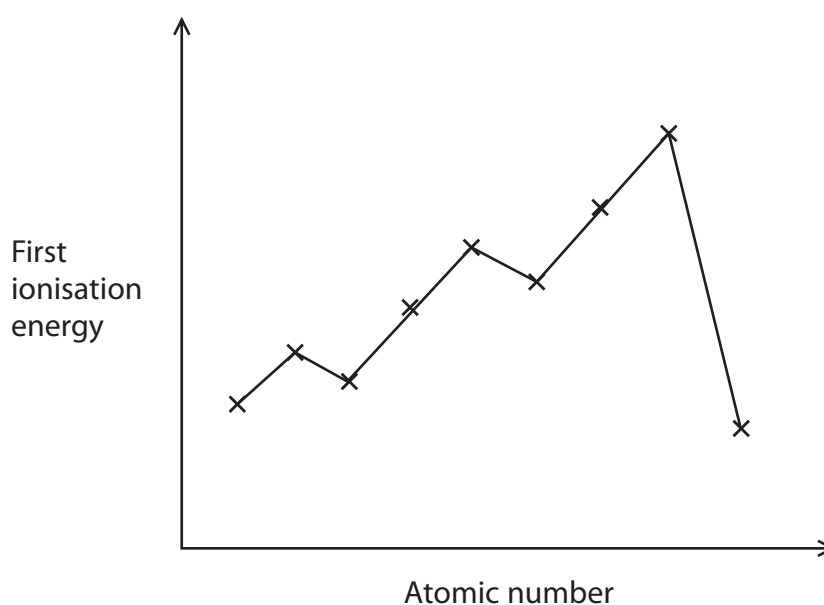

(i) Circle **all** the crosses on the sketch which represent electrons being removed from an s orbital.

(2)

DO NOT WRITE IN THIS AREA

DO NOT WRITE IN THIS AREA

DO NOT WRITE IN THIS AREA

DO NOT WRITE IN THIS AREA

DO NOT WRITE IN THIS AREA

DO NOT WRITE IN THIS AREA



(ii) Draw the shape of a single p orbital.

(1)

\* (d) Describe the trend in the values of the first four ionisation energies for the element aluminium. Hence show that aluminium is in Group 3 of the Periodic Table.

(2)

.....

.....

.....

.....

.....

.....

.....

.....

(e) Why are orbitals of the same sub shell occupied singly by electrons, before pairing of electrons occurs?

(1)

.....

.....

.....

.....

**(Total for Question 18 = 9 marks)**



19 The following data can be used in a Born-Haber cycle for calcium oxide, CaO.

Letter	Enthalpy change	Value / $\text{kJ mol}^{-1}$
A	Enthalpy change of atomisation of calcium	+178
B	First ionisation energy of calcium	+590
C	Second ionisation energy of calcium	+1145
D	Enthalpy change of formation of calcium oxide	-635
E	Enthalpy change of atomisation of oxygen ( $\frac{1}{2}\text{O}_2(\text{g}) \rightarrow \text{O}(\text{g})$ )	+249
F	First electron affinity of oxygen	-141
G	Second electron affinity of oxygen	+798

(a) Complete the Born-Haber cycle for calcium oxide by adding

- letters in the boxes for the ionisation energies of calcium and the electron affinities of oxygen
- any relevant chemical species and electrons on the blank lines
- arrow heads to indicate enthalpy change direction

(3)

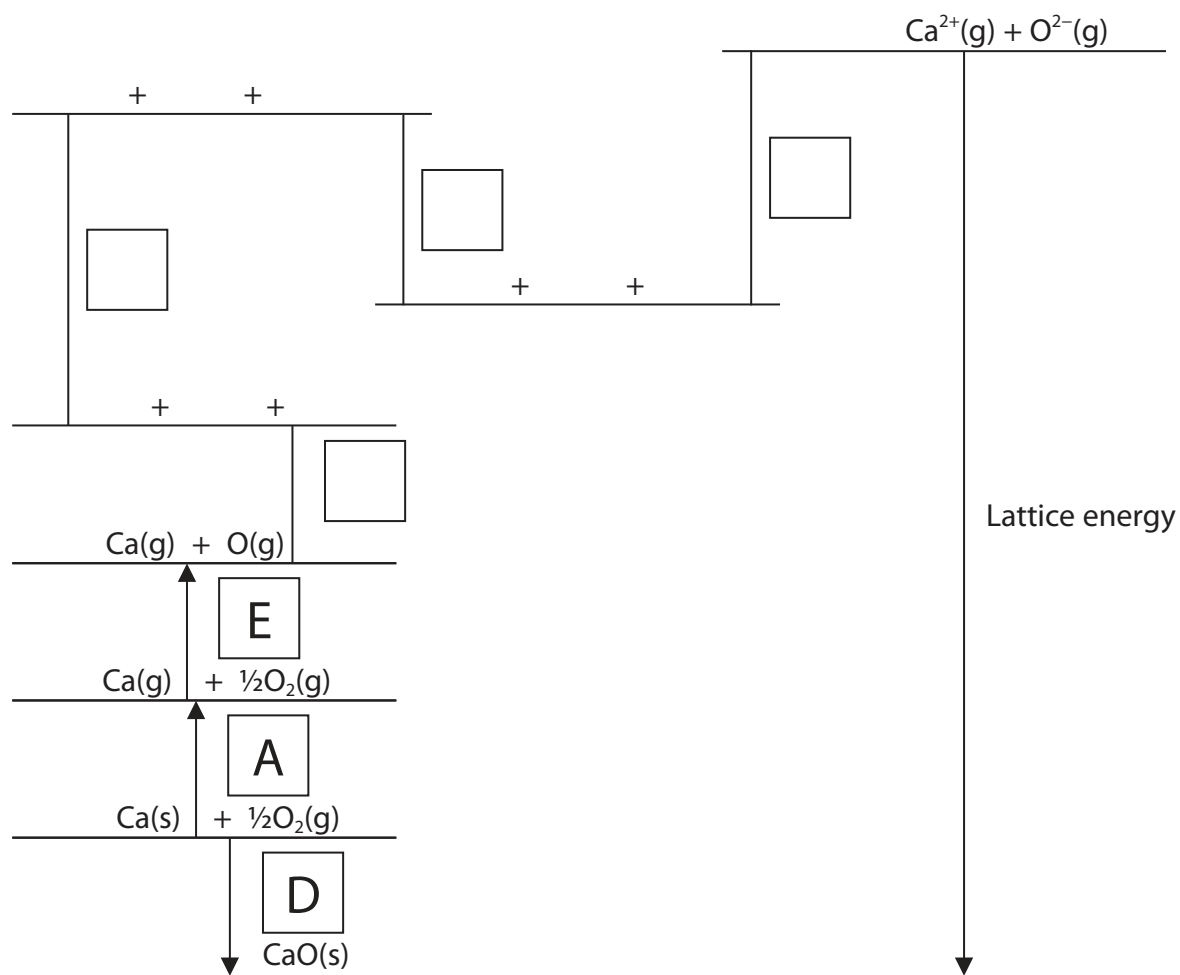



(d) The reaction between calcium oxide and water to produce calcium hydroxide is exothermic, and is used to warm canned drinks. A typical arrangement is shown in the diagram.

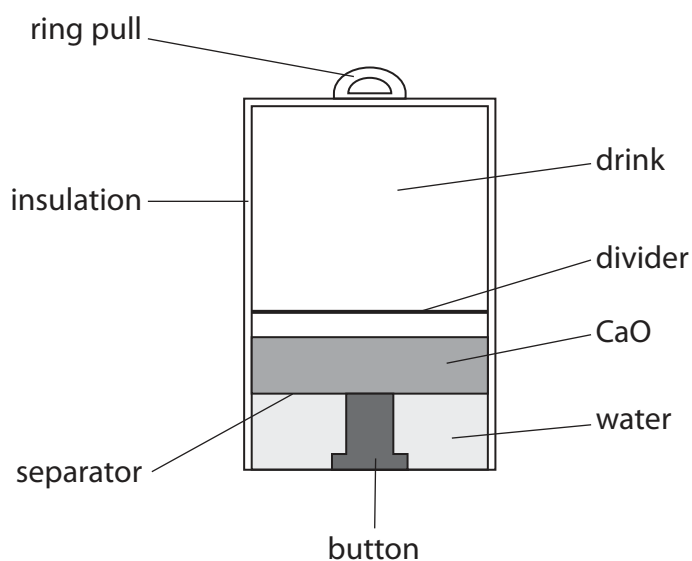

The enthalpy change of reaction is  $-65.1 \text{ kJ mol}^{-1}$

Assume that the energy transferred to the drink is given by the following equation:

$$\text{energy (J)} = \text{volume of drink (cm}^3\text{)} \times 4.18 \text{ (J cm}^{-3}\text{ }^\circ\text{C}^{-1}\text{)} \times \text{temperature change (}^\circ\text{C)}$$

(i) Calculate the mass of calcium oxide that would be required to raise the temperature of  $200 \text{ cm}^3$  of drink by  $40^\circ\text{C}$ .

(3)

(ii) Give **two** reasons why this drink can is insulated.

(2)

.....

.....

.....

.....

DO NOT WRITE IN THIS AREA

DO NOT WRITE IN THIS AREA

DO NOT WRITE IN THIS AREA

DO NOT WRITE IN THIS AREA

DO NOT WRITE IN THIS AREA

DO NOT WRITE IN THIS AREA



(iii) Complete the enthalpy level diagram for the reaction between calcium oxide and water. Include state symbols, the value for the enthalpy change and a label for the y axis.

(2)

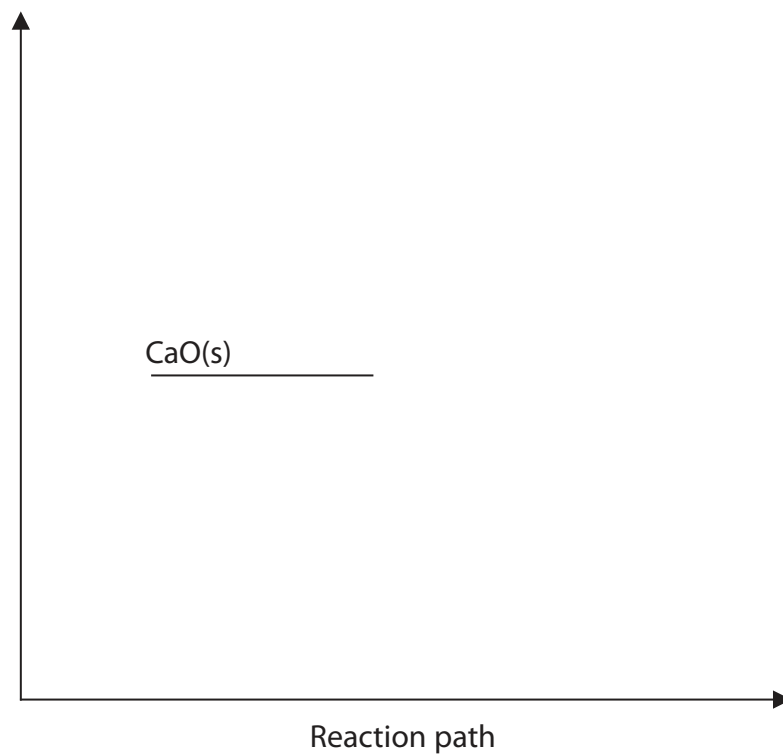

(Total for Question 19 = 16 marks)

**TOTAL FOR SECTION B = 60 MARKS**  
**TOTAL FOR PAPER = 80 MARKS**



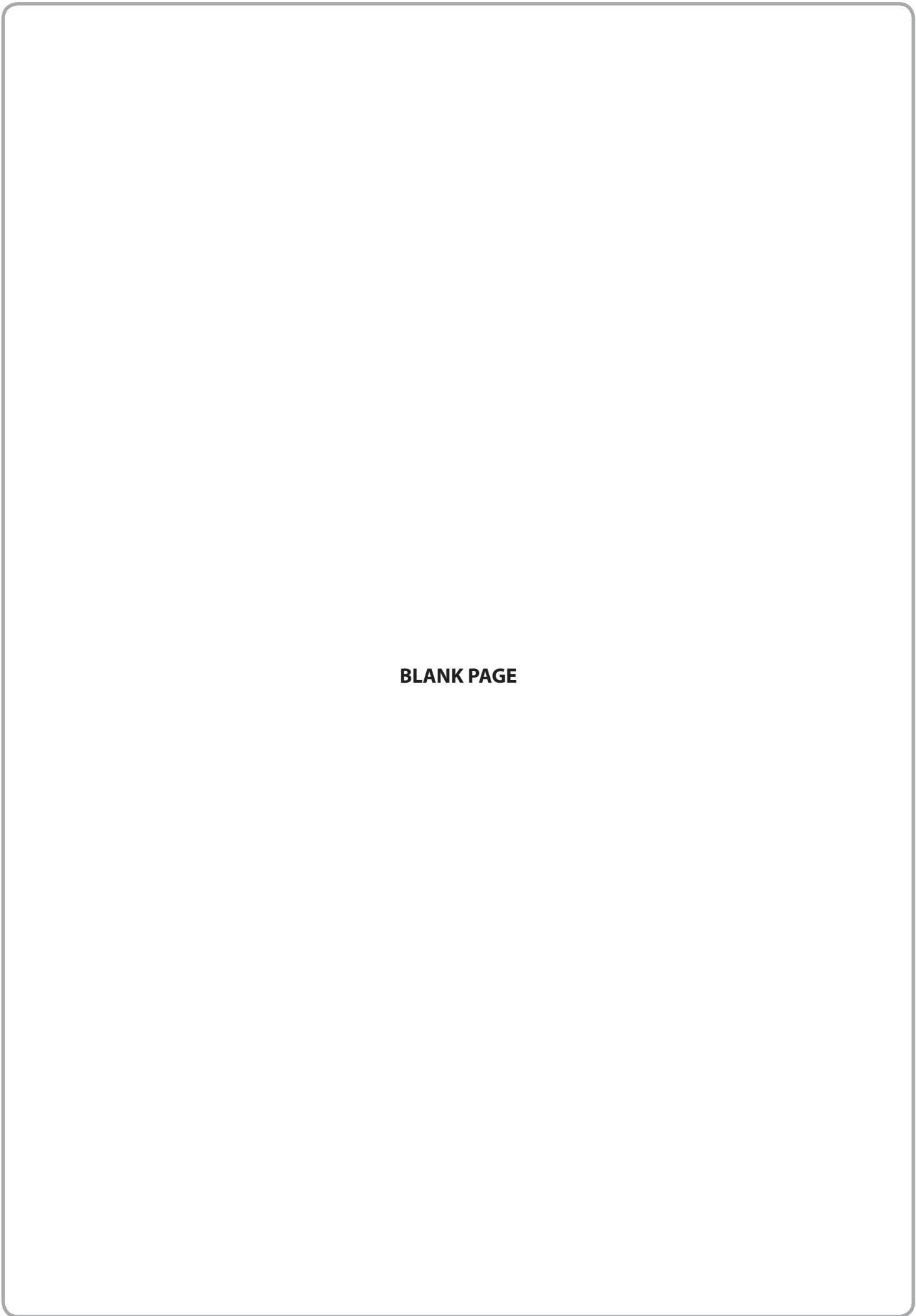

**BLANK PAGE**

DO NOT WRITE IN THIS AREA

DO NOT WRITE IN THIS AREA

DO NOT WRITE IN THIS AREA

DO NOT WRITE IN THIS AREA

DO NOT WRITE IN THIS AREA

DO NOT WRITE IN THIS AREA





DO NOT WRITE IN THIS AREA

DO NOT WRITE IN THIS AREA

DO NOT WRITE IN THIS AREA

DO NOT WRITE IN THIS AREA

DO NOT WRITE IN THIS AREA

DO NOT WRITE IN THIS AREA

**BLANK PAGE**



